

ROOF INSTALLATION OVERVIEW SIMPLE SAVER SYSTEM®



601 North Main Street | PO Box 468 | Madison, NE 68748
800.255.0776 | thermaldesign.com

Please follow complete manufacturers instructions for safety, performance and effectiveness. The following information and detail overview is how our insulation and finishing systems are installed and shall only be used to understand the basic process.

Step 1: Cut the required number of UVMAX® steel straps to proper lengths. Pull the straps to the far endwall, over each rafter. Fasten each longitudinal steel strap to the far endwall rafter of the building, then return and fasten the straps to the near endwall rafter.

Note: Always use two fasteners 3" apart with fall protection systems!

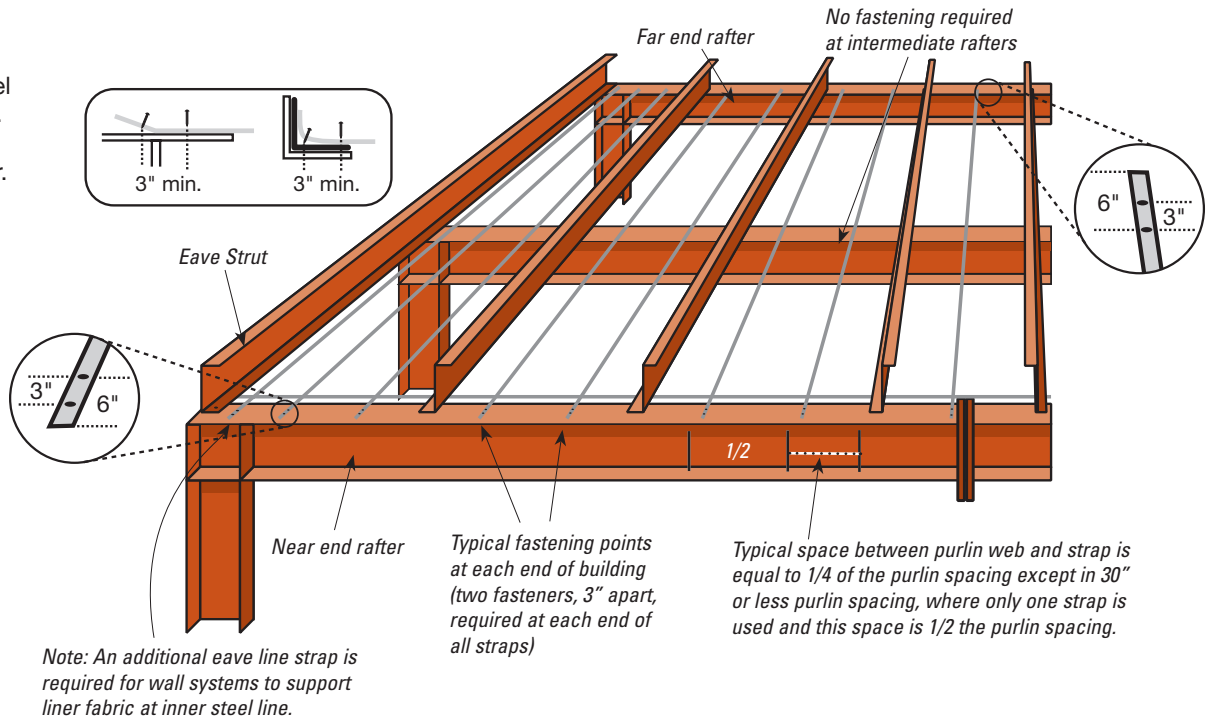

Step 2: Pull traverse straps across building width, over every 6th or 8th longitudinal strap, and over the ridge straps. Fasten one end of each traverse steel strap to the bottom of the sidewall eave purlins on one side of the building with two fasteners. Pull each strap hand tight to one ridge purlin, fasten strap, then pull each strap hand tight to the opposite eave and fasten.

Typical traverse strap spacing is the bay length divided by five or six. Additionally, the fall protection certified system requires a strap 6" away from each rafter flange to secure the edges of the liner fabric in each bay. See project drawings for specified spacing.

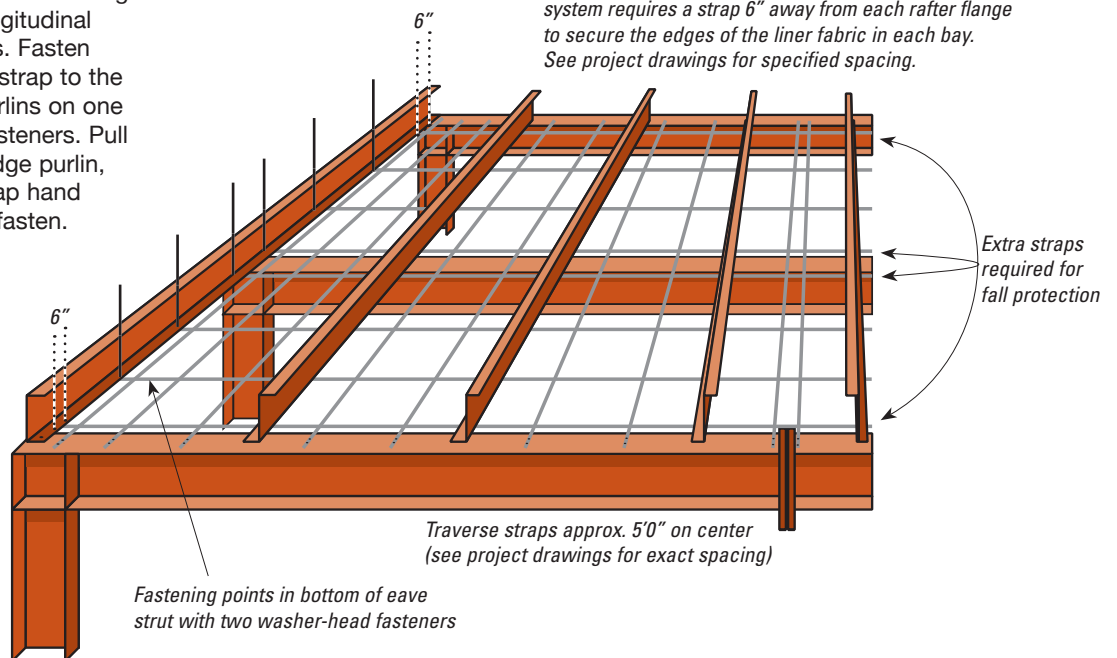

Step 3: Place the Syseal® liner fabric on the steel strap platform in the eave purlin space and clamp two corners of the fabric. Feed the other end of the fabric underneath the purlins and pull tightly over the platform of straps to the ridge. Fasten the fabric and straps to the bottom of the nearest ridge purlin then continue to pull the fabric to the opposite eave purlin. Fasten all straps at purlin intersections.

Important: Keep fabric square with eave!

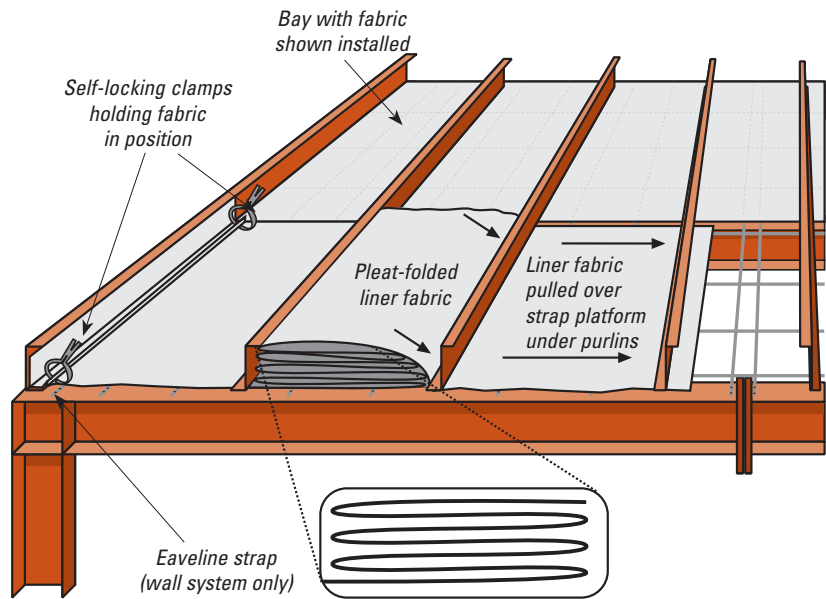

Step 4: Trim the edges of the fabric to fit around the points where the purlins are fastened to the rafters and seal the fabric to the top of the rafters with contact sealant.

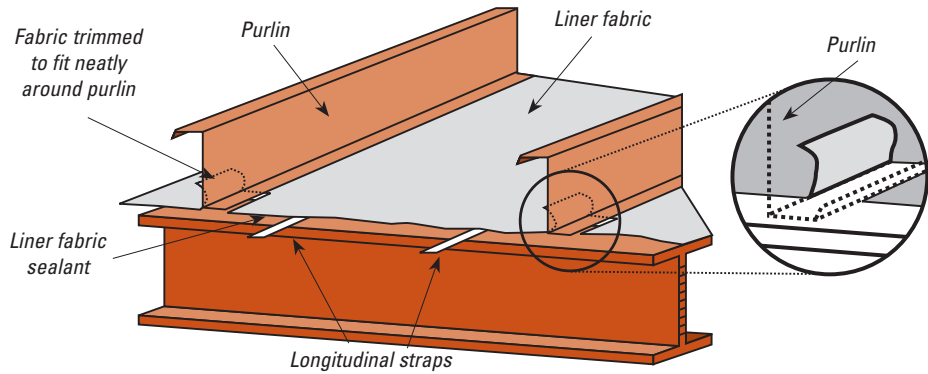

Step 5: Install the insulation material onto the Syseal® fabric to completely fill the purlin spaces. If desired, a second layer of insulation may be installed over the purlins.

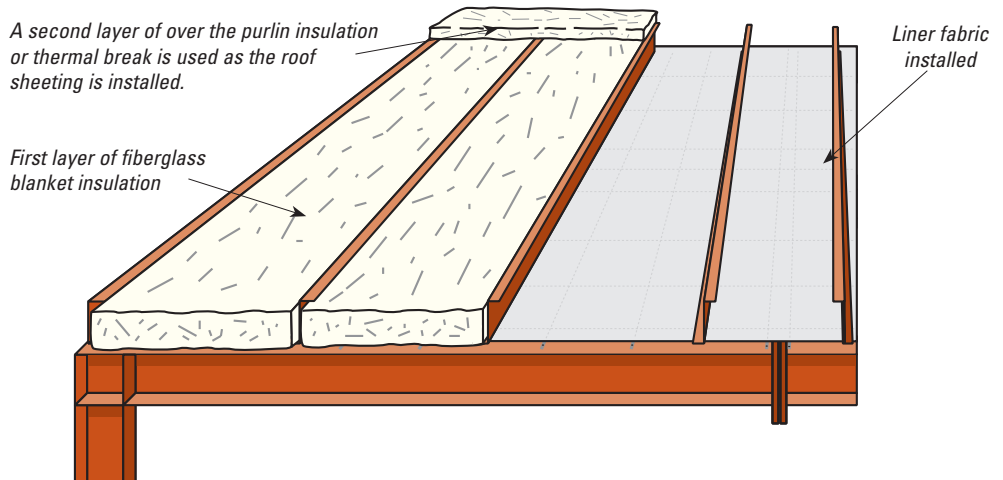

Rafter Brace Details: Specify one detail shown when ordering building.

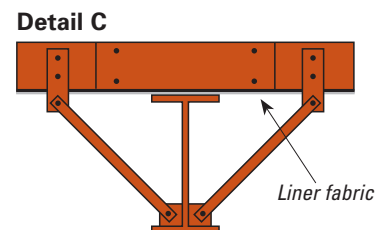
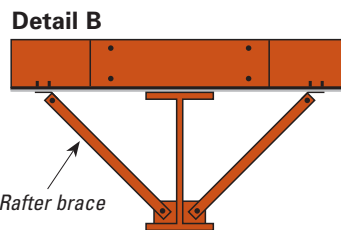
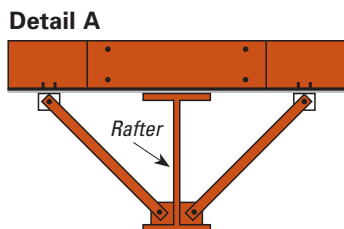

Brace clips are typically directly fastened using fasteners unless otherwise specified.